

inspired LED *Insight Series Round LED Can Light*

The **Insight Series LED Can Lights** combine the efficiency and energy-saving benefits of 24V LEDs with the sleek look of traditional recessed can lights. This lightweight, freeform design requires no additional housing, simplifying the process of installation and reducing time and labor costs. Unlike other products currently on the market, the Insight LED can lights operate on a true low-voltage system rated to last up to 50,000 hours, while producing minimal heat and eliminating the need for regular bulb replacement.

Mechanical Specifications:

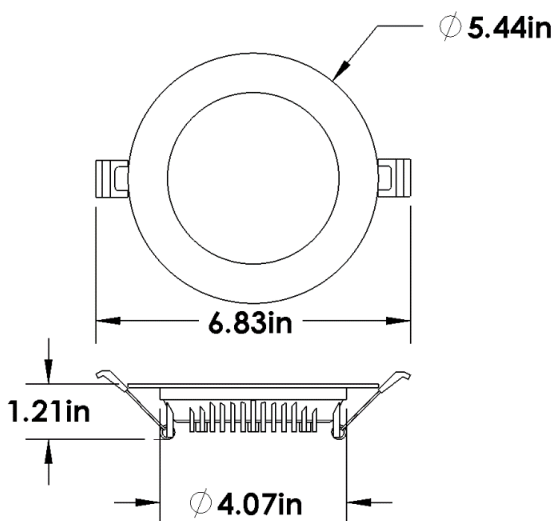

Installation Instructions:

- To install**, create a 4.25" - 4.5" diameter hole in wall or ceiling, large enough to insert LED can fixture (stencil available on backside of spec sheet).
- Connect wires from the LED can fixture to 24VDC power source, using wire nuts, and matching polarities accordingly (*red (+), black (-)*).
- Lift orange spring clips into upright position and insert the LED can light into designated hole.
- Gently allow spring clips to release inside the mounting hole so the product is held stationary and flush to the surface. *To prevent connection issues do not twist fixture once installed.*



Warm SKU# 3876
Pure SKU# 3961

Product Features:

- Flush mount 4" \varnothing lens
- Compatible with 24VDC power supplies and hardwire dimmable transformers
- Available in warm (~2900K) and pure (~4000K)
- Produces 1,000 lumens per can
- Dimmable with compatible systems
- Rated to last up to 50,000 hours
- 1 foot 22 AWG bare flying lead included
- 16-22 AWG connection recommended
- For indoor use

Electrical Specifications:

	Warm White	Pure White
Input Voltage:	24VDC	24VDC
Wattage:	~9.3W	~9.3W
Color Temp:	~2900K	~4000K
Lumen Output:	~1,000 lm	~1,000 lm
Lumens per Watt	~110 lm/W	~110 lm/W
CRI:	~82 CRI	~81 CRI
Wiring Type:	22AWG	22AWG

Wiring Diagrams:

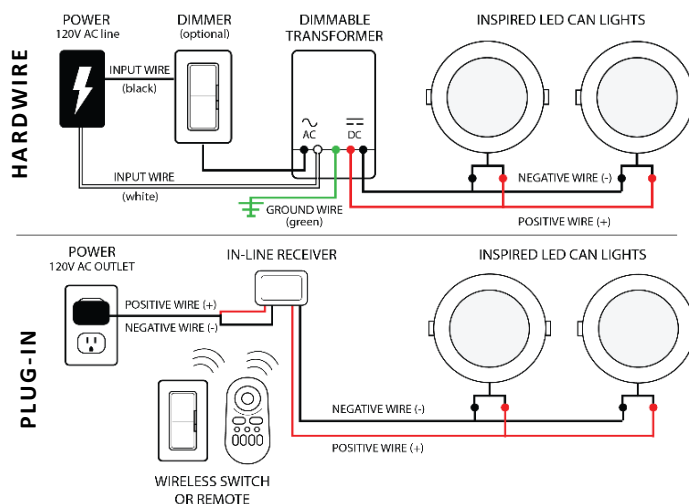

inspired LED

Insight Can Light Template & Quick Specs:

Input:	24V DC
Wattage:	~9.3W per fixture
Lumens:	~1,000lm per fixture
Wiring:	16-22 AWG

1. **To install**, use stencil or compass to draw a 4.25" diameter hole in wall or ceiling and use a saw or circular drill to carefully cut out hole.
2. Connect wires from the LED can fixture to 24VDC power source, using wire nuts, and matching polarities accordingly (*red (+), black (-)*).
3. Lift orange spring clips into upright position and insert the LED can light into designated hole.
4. Gently allow spring clips to release inside the mounting hole so the product is held stationary and flush to the surface. *To prevent connection issues do not twist fixture once installed.*

