

200W M-Series Driver

Indoor & Outdoor Magnetic Dimmable Transformer

Product Code: M200L12DC-AR

iLED SKU#: 3934

Magnitude's M200L12DC-AR is the most compact LED driver on the market with a magnetic transformer core. It is equipped with two auto-reset breakers, one on the input and one on the output to protect both the load and driver. The driver is encased in a coated metal box that includes four knock-outs on the bottom for easy installation which complies with electrical code requirements.

Features

- Dimmable with standard MLV/TRIAC (leading edge) dimmer switch
- Dual protection – two manual push-to-reset circuit breakers
- Nema 3R Enclosure- Outdoor Use
- Four bottom knock-outs
- Optional 10% voltage boost to compensate for voltage drop
- ETL Listed, Certified to CSA Standard, UL 8750

Specifications

50% Load is required if not being used with a dimmer.

Max Load	200W
Input Voltage	120V AC
Input Current at Max Load	2.13 A
Output Voltage	12V DC
Output Current at Max Load	15.6 A
Open Circuit Output Voltage	12.9V DC
Avg. Efficiency	>85%
Power Factor	>0.92
Coil Former	Double Section Bobbin
Max Ambient Temperature	-30°C to 45°C
Min Installation Space btw Drivers	5 inches
Thermal Class	B130°C
Leads Primary	PVC 600V #18
Leads Secondary	PVC 300V #12
Dimensions (inch)	10.6" x 3.9" x 2.84"
Weight	87 oz.

Wiring Diagram

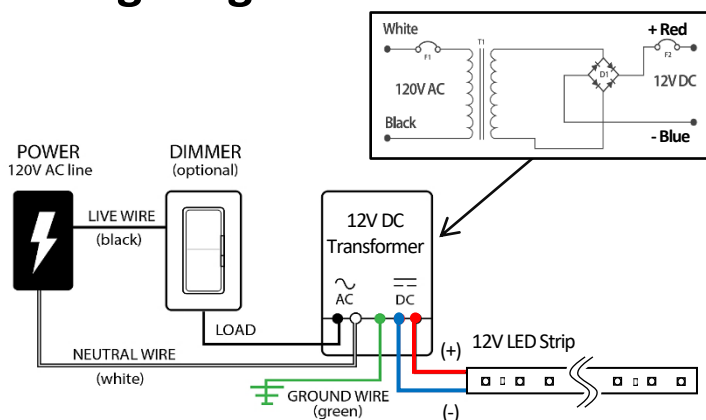

BEFORE YOU BEGIN

Note: This dimmable transformer requires a **compatible magnetic low voltage (MLV)/ incandescent TRIAC wall dimmer** for proper operation. See the list of approved dimmers recommended by Magnitude Inc. and Inspired LED. Driver must be installed in a well-ventilated area free from explosive gasses and vapors. Proper operation requires a free flow of air. Driver should be installed by a qualified electrician in accordance with article 450 of the National Electrical Code.

Precautions Before Installing

Check the label to ensure the driver has the proper input voltage and wattage for the job. Check the wire markings to ensure they match the wiring diagram below.

Input Connections/Grounding

Remove the wiring compartment knockouts and install the clamp connectors provided with the driver. With power turned off, route the input wires through the clamp connector and connect one wire to black and one wire to white. For all wire connections use only UL listed wire nuts and connectors of suitable size and style. Connect the ground wire to the driver green wire, **the driver case MUST be grounded in accordance with N.E.C.**

Output Connections

Bring the wires of the light fixture through the other clamp connector and connect them to the driver wire- positive to the **red (+)** wire and negative to the **blue (-)** wire.

Mounting

Select a location capable of supporting the weight of the driver. Use the two keyholes in in the driver case to mount using suitable screws. It is recommended that the driver be mounted vertically with the wiring compartment pointing down.

Output Voltage vs. Load

