

inspired LED

24V Flexible LED Strip Lights

Mega Bright 240Ω  [®]
C US
265216

For extended length accent lighting...

Inspired LED's 24 Volt Mega Bright 240ohm Flexible LED Strips are ideal for those applications requiring extra-long runs of indirect light. Available in custom lengths or 12m reels, these unique strips can be cut to length and terminated with solderless connectors for easy DIY installation. Energy efficient, long lasting, and dimmable with compatible systems, Inspired LED flex strips are the perfect way to put the finishing touches on any project!



Warm White Pure White

Specifications:	Voltage	LED Density	Wattage	Luminosity	Color Temp	CRI
Warm White	24V	36 LEDs/ft., 120 LEDs/m	2.5 W/ft.	195 lm/ft.	2800 K	93
Pure White	24V	36 LEDs/ft., 120 LEDs/m	2.5 W/ft.	245 lm/ft.	4000 K	94

Product Features:

- Size 2835 diodes, 0.33" spacing between each LED
- 10mm flex, cut points available every 2" (6 LEDs)
- Available in custom pre-cut lengths or full 12m reels
- Class 2 DC plug-in connectors (3.5 x 1.3 mm) or screw terminal end connectors available
- Adhesive backing mounts to almost any flat surface
- Minimal heat production, no IR or UV output
- Dimmable with compatible systems
- Rated to last up to 100,000 hours
- CSA C22.2 No. 250.0-08/ANSI/ UL Standard 1598, 8750
- **To be installed in accordance with NEC, using Class 2 24V power supply!**

Product Dimensions:

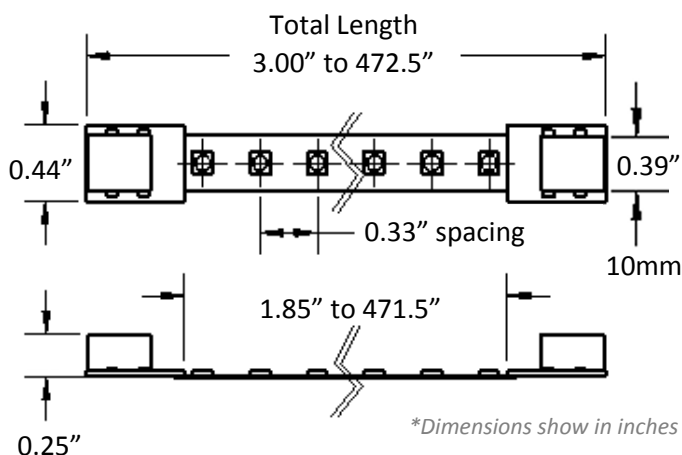

Power Requirements:

Power Source	Max Length
3.75 Amp Plug-in	405.5" (80 W)
96W Transformer	458.75" (86 W)
150W Transformer	720" (135 W)
300W Transformer	1440" (270 W)

*Individual strips over 150" should be powered from the center, strips should not exceed 300"

Installation Instructions:

1. Clean desired mounting surface(s) and test all products prior to installation.
2. Temporarily mount LED flex strips using scotch or painters tape.
3. Connect LED strips with compatible interconnect cables or 16-22 AWG wire.
4. Run cable from LED system to control device and 12V Class 2 power source (see diagrams below for more detail).
5. Test lighting system. When satisfied with placement, peel adhesive backing from components and press firmly to adhere to surface.

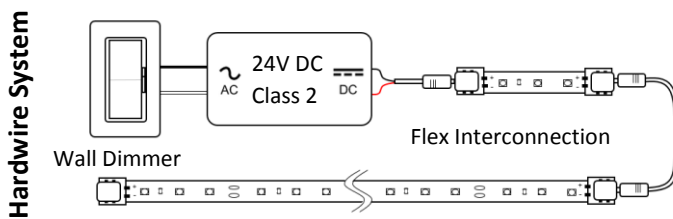
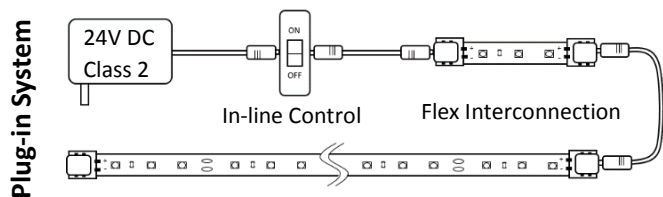

inspiredled.com



orders@inspiredled.com



(480) 941-4286